

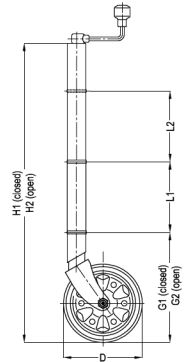

626100

6 x 2 JOCKEY WHEEL c/w CLAMP



WEIGHT (KG)	SURFACE FINISH	STATIC CAPACITY (KG)	OUTER TUBE DIAMETER	D (mm)	H 1 (mm)	H 2 (mm)	G 1 (mm)	G 2 (mm)	L 1 (mm)
5.5	ZINC PLATED	400KG	48mm	150	507	772	202	467	182



628100

8 x 2 JOCKEY WHEEL c/w CLAMP

WEIGHT (KG)	SURFACE FINISH	STATIC CAPACITY (KG)	OUTER TUBE DIAMETER	D (mm)	H 1 (mm)	H 2 (mm)	G 1 (mm)	G 2 (mm)	L 1 (mm)
7	ZINC PLATED	400KG	48mm	200	567	832	262	522	182



628325

8 x 2 EX. HEIGHT JOCKEY WHEEL c/w CLAMP

WEIGHT (KG)	SURFACE FINISH	STATIC CAPACITY (KG)	OUTER TUBE DIAMETER	D (mm)	H 1 (mm)	H 2 (mm)	G 1 (mm)	G 2 (mm)	L 1 (mm)
7	ZINC PLATED	400KG	48mm	200	730	995	370	635	132

Helpful Hint:

Use a large wheel for soft ground!



626204

6 x 2 JOCKEY WHEEL c/w SMALL DOUBLE LOCKING PIN BRACKET

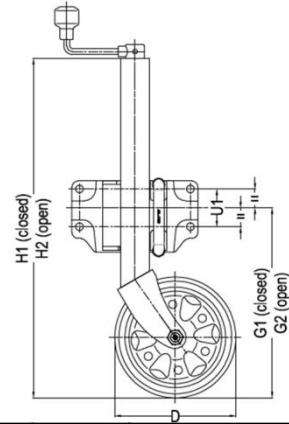

WEIGHT (KG)	SURFACE FINISH	STATIC CAPACITY (KG)	OUTER TUBE DIAMETER	D (mm)	H 1 (mm)	H 2 (mm)	G 1 (mm)	G 2 (mm)	U (mm) HOLE SIZE (ø14)
									U 1
									FOR DRAW BAR DEPTH
									50mm
7	ZINC PLATED	400KG	48mm	150	510	760	300	525	63



628204

8 x 2 JOCKEY WHEEL c/w SMALL DOUBLE LOCKING PIN BRACKET

WEIGHT (KG)	SURFACE FINISH	STATIC CAPACITY (KG)	OUTER TUBE DIAMETER	D (mm)	H 1 (mm)	H 2 (mm)	G 1 (mm)	G 2 (mm)	U (mm) HOLE SIZE (ø14)
									U 1
									FOR DRAW BAR DEPTH
									50mm
8.5	ZINC PLATED	400KG	48mm	200	570	820	310	560	63

Helpful Hint:

Use a large wheel for soft ground!



628200XP3
8 x 2 SOLID TYRE JOCKEY
WHEEL c/w 3 BOLT DOUBLE
LOCKING PIN SWIVEL BRACKET

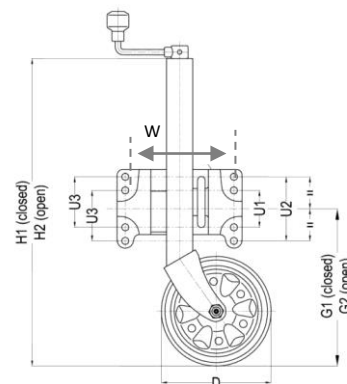

WEIGHT (KG)	SURFACE FINISH	STATIC CAPACITY (KG)	OUTER TUBE DIAMETER	D (mm)	H 1 (mm)	H 2 (mm)	G 1 (mm)	G 2 (mm)	W (mm)	U (mm) HOLE SIZE (ø14)		
										U 1	U 2	U 3
										FOR DRAW BAR DEPTH		
										50 mm	100 mm	75 mm
8.5	ZINC PLATED	400KG	48mm	200	570	820	305	522	185	63	113	88



623660XP3
250 x 80 SOLID TYRE JOCKEY
WHEEL c/w 3 BOLT DOUBLE
LOCKING PIN SWIVEL BRACKET

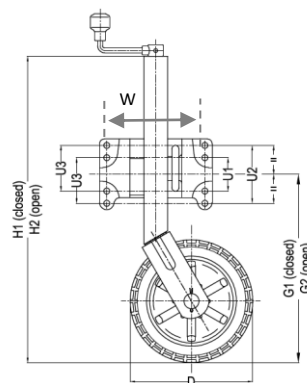

WEIGHT (KG)	SURFACE FINISH	STATIC CAPACITY (KG)	OUTER TUBE DIAMETER	D (mm)	H 1 (mm)	H 2 (mm)	G 1 (mm)	G 2 (mm)	W (mm)	U (mm) HOLE SIZE (ø14)		
										U 1	U 2	U 3
										FOR DRAW BAR DEPTH		
										50 mm	100 mm	75 mm
11	ZINC PLATED	400KG	48mm	250	630	880	320	570	185	63	113	88



628500
8 x 2 PREMIUM SIDE WIND JOCKEY
WHEEL c/w EXTRA WIDE CLAMP

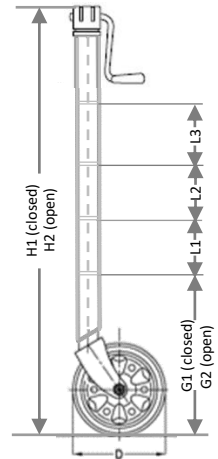

WEIGHT (KG)	SURFACE FINISH	STATIC CAPACITY (KG)	OUTER TUBE DIAMETER	D (mm)	H 1 (mm)	H 2 (mm)	G 1 (mm)	G 2 (mm)	L 1 (mm)	L 2 (mm)	L 3 (mm)
9.1	ZINC PLATED	400KG	48mm	200	771	1037	320	586	85	85	85



621250
250 x 80 SOLID TYRE POWER
MOVER JOCKEY WHEEL c/w CLAMP

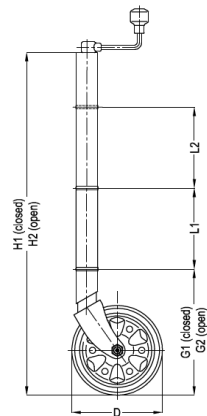

WEIGHT (KG)	SURFACE FINISH	STATIC CAPACITY (KG)	DYNAMIC CAPACITY (KG)	OUTER TUBE DIAMETER	D (mm)	H 1 (mm)	H 2 (mm)	G 1 (mm)	G 2 (mm)	L 1 (mm)	L 2 (mm)
14.7	ZINC PLATED	350KG	150KG	48mm	245	625	875	335	585	85	85

Helpful Hint: Use a large wheel for soft ground!



626050
T/T 6 x 2 LIGHT DUTY JOCKEY
WHEEL c/w CLAMP

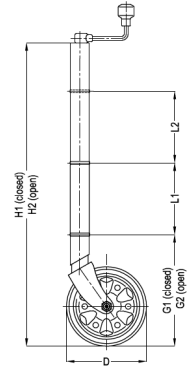

WEIGHT (KG)	SURFACE FINISH	STATIC CAPACITY (KG)	OUTER TUBE DIAMETER	D (mm)	H 1 (mm)	H 2 (mm)	G 1 (mm)	G 2 (mm)	L 1 (mm)
5	ZINC PLATED	350KG	48mm	150	510	760	202	457	180



629250TT
T/T 250 x 80 ZINC PLATED SOLID TYRE
JOCKEY WHEEL c/w CLAMP

WEIGHT (KG)	SURFACE FINISH	STATIC CAPACITY (KG)	OUTER TUBE DIAMETER	D (mm)	H 1 (mm)	H 2 (mm)	G 1 (mm)	G 2 (mm)	L 1 (mm)
8	ZINC PLATED	350KG	48mm	245	635	885	325	575	180

Helpful Hint:

Use a large wheel for soft ground!

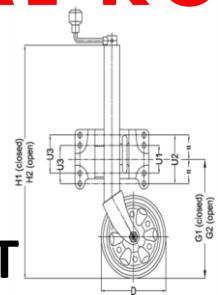

626190

**T/T 6 x 2 LIGHT DUTY JOCKEY WHEEL
c/w LARGE DOUBLE LOCKING PIN BRACKET**



WEIGHT (KG)	SURFACE FINISH	STATIC CAPACITY (KG)	OUTER TUBE DIAMETER	D (mm)	H 1 (mm)	H 2 (mm)	G 1 (mm)	G 2 (mm)	U (mm) HOLE SIZE (ø14)		
									U 1	U 2	U 3
									FOR DRAW BAR DEPTH		
									50 mm	100 mm	75 mm
6.75	ZINC PLATED	350KG	48mm	150	510	760	310	560	63	113	88

628200SLTT

**T/T 8 x 2 ZINC PLATED JOCKEY WHEEL
c/w LARGE DOUBLE LOCKING PIN BRACKET**



WEIGHT (KG)	SURFACE FINISH	STATIC CAPACITY (KG)	OUTER TUBE DIAMETER	D (mm)	H 1 (mm)	H 2 (mm)	G 1 (mm)	G 2 (mm)	U (mm) HOLE SIZE (ø14)		
									U 1	U 2	U 3
									FOR DRAW BAR DEPTH		
									50 mm	100 mm	75 mm
7.5	ZINC PLATED	350KG	48mm	200	570	820	310	560	63	113	88

629250SLTT

**T/T 250 x 80 ZINC PLATED JOCKEY WHEEL
c/w LARGE DOUBLE LOCKING PIN BRACKET**



WEIGHT (KG)	SURFACE FINISH	STATIC CAPACITY (KG)	OUTER TUBE DIAMETER	D (mm)	H 1 (mm)	H 2 (mm)	G 1 (mm)	G 2 (mm)	U (mm) HOLE SIZE (ø14)		
									U 1	U 2	U 3
									FOR DRAW BAR DEPTH		
									50 mm	100 mm	75 mm
10.5	ZINC PLATED	350KG	48mm	245	630	880	395	645	63	113	88

622455

500KG FLIP UP JOCKEY WHEEL c/w BRACKET



WEIGHT (KG)		SURFACE FINISH		STATIC CAPACITY (KG)		DYNAMIC CAPACITY (KG)		WHEEL DIM. & WIDTH (mm)	
10		ZINC PLATED		500KG		300KG		200 x 50	
DIM. A		DIM. B		DIM. C (MAX. TRAVEL) (mm)		DIM. D (OUTER TUBE DIAMETER)		DIM. E (mm)	
MIN. (mm)	MAX. (mm)	MIN. (mm)							
730	975	840	245		60mm		410		
DIM. F (mm)	DIM. G (mm)	DIM. H (mm)	DIM. K (mm)	DIM. L (mm)	DIM. M (MIN. mm)	DIM. N (mm)			
300	145	330	235	90	75	140			

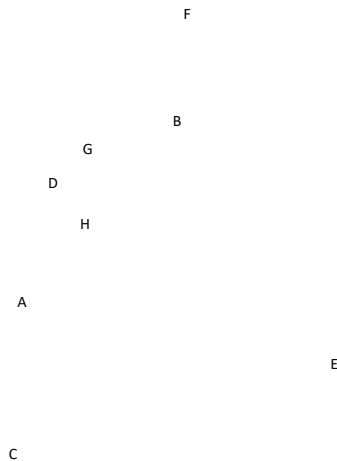
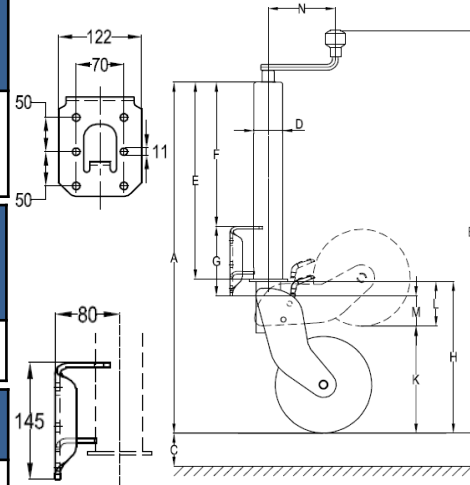

629900 JOCKEY WHEEL CLAMP



WEIGHT (KG)	SURFACE FINISH	OUTER TUBE DIAMETER	A (mm)	B ϕ (mm)
1	ZINC PLATED	48mm	150	13

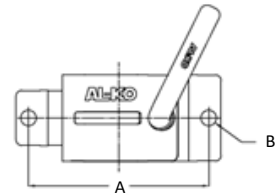

629920 LARGE DOUBLE LOCKING PIN BRACKET



WEIGHT (KG)	SURFACE FINISH	STATIC CAPACITY (KG)	OUTER TUBE DIAMETER	A (mm)	B (mm)	C (mm)	D (mm)
2.5	ZINC PLATED	400KG	48mm	185	88	63	113

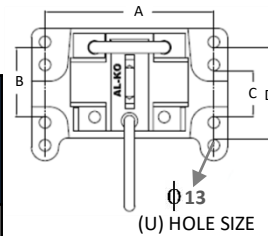

629923 SWIVEL BRACKET 3 BOLT LARGE



WEIGHT (KG)	SURFACE FINISH	STATIC CAPACITY (KG)	OUTER TUBE DIAMETER	A (mm)	B (mm)	C (mm)	D (mm)
2.65	ZINC PLATED	400KG	48mm	185	88	63	113

629935 DOUBLE LOCKING PIN BRACKET c/w CLAMP



WEIGHT (KG)	SURFACE FINISH	OUTER TUBE DIAMETER	A (mm)	B (mm)	C (mm)	D (mm)
3.3	ZINC PLATED	48mm	185	75	50	100



629600
6 x 2 SOLID
RUBBER WHEEL











629888
8 x 2 STEEL/
RUBBER WHEEL



629850
250 x 80 STEEL/
RUBBER WHEEL

Helpful Hint: Use a large wheel for soft ground!

PART NO.	DESCRIPTION	
626262	JOCKEY WHEEL U.BOLT KIT (75mm x 75mm)	
626260	JOCKEY WHEEL U.BOLT KIT (100mm x 75mm)	
629910	AK JOCKEY WHEEL MANOEUVRING HANDLE	
629915	AK JOCKEY WHEEL PREMIUM WIDE CLAMP (SPACING: 150mm x 50mm ; HOLE SIZE: 13mm)	
629602	STD. THRUST BEARING	
629601GS	JOCKEY WHEEL HANDLE c/w GRUB SCREW	
629601RP	JOCKEY WHEEL HANDLE c/w ROLL PIN	
629951	CLAMP HANDLE & BOLT	
629605	SCREWED SHAFT ONLY	