

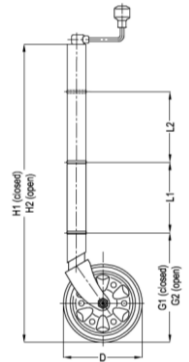

626100

6 x 2 JOCKEY WHEEL c/w CLAMP



WEIGHT (KG)	SURFACE FINISH	STATIC CAPACITY (KG)	OUTER TUBE DIAMETER	D (mm)	H 1 (mm)	H 2 (mm)	G 1 (mm)	G 2 (mm)	L 1 (mm)
5.5	ZINC PLATED	400KG	48mm	150	507	772	202	467	182



628100

8 x 2 JOCKEY WHEEL c/w CLAMP

WEIGHT (KG)	SURFACE FINISH	STATIC CAPACITY (KG)	OUTER TUBE DIAMETER	D (mm)	H 1 (mm)	H 2 (mm)	G 1 (mm)	G 2 (mm)	L 1 (mm)
7	ZINC PLATED	400KG	48mm	200	567	832	262	522	182



628325

8 x 2 EX. HEIGHT JOCKEY WHEEL c/w CLAMP

WEIGHT (KG)	SURFACE FINISH	STATIC CAPACITY (KG)	OUTER TUBE DIAMETER	D (mm)	H 1 (mm)	H 2 (mm)	G 1 (mm)	G 2 (mm)	L 1 (mm)
7	ZINC PLATED	400KG	48mm	200	730	995	370	635	132

Helpful Hint:

Use a large wheel for soft ground!



626204

6 x 2 JOCKEY WHEEL c/w SMALL DOUBLE LOCKING PIN BRACKET

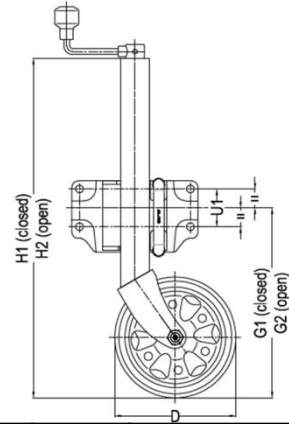

WEIGHT (KG)	SURFACE FINISH	STATIC CAPACITY (KG)	OUTER TUBE DIAMETER	D (mm)	H 1 (mm)	H 2 (mm)	G 1 (mm)	G 2 (mm)	U (mm) HOLE SIZE (ø14)
									U 1
									FOR DRAW BAR DEPTH
									50mm
7	ZINC PLATED	400KG	48mm	150	510	760	300	525	63



628204

8 x 2 JOCKEY WHEEL c/w SMALL DOUBLE LOCKING PIN BRACKET

WEIGHT (KG)	SURFACE FINISH	STATIC CAPACITY (KG)	OUTER TUBE DIAMETER	D (mm)	H 1 (mm)	H 2 (mm)	G 1 (mm)	G 2 (mm)	U (mm) HOLE SIZE (ø14)
									U 1
									FOR DRAW BAR DEPTH
									50mm
8.5	ZINC PLATED	400KG	48mm	200	570	820	310	560	63

Helpful Hint:

Use a large wheel for soft ground!

622455

500KG FLIP UP JOCKEY WHEEL c/w BRACKET

WEIGHT (KG)		SURFACE FINISH		STATIC CAPACITY (KG)		DYNAMIC CAPACITY (KG)		WHEEL DIM. & WIDTH (mm)	
10		ZINC PLATED		500KG		300KG		200 x 50	
DIM. A		DIM. B		DIM. C (MAX. TRAVEL) (mm)	DIM. D (OUTER TUBE DIAMETER)	DIM. E (mm)			
MIN. (mm)	MAX. (mm)	MIN. (mm)							
730	975	840	245	60mm	410				
DIM. F (mm)	DIM. G (mm)	DIM. H (mm)	DIM. K (mm)	DIM. L (mm)	DIM. M (MIN. mm)	DIM. N (mm)			
300	145	330	235	90	75	140			

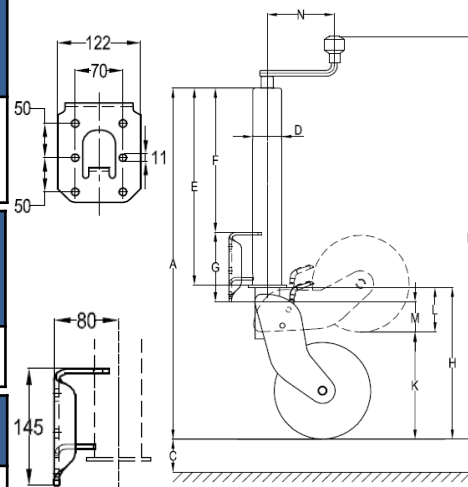

622800

800KG FLIP UP JOCKEY WHEEL c/w BRACKET

WEIGHT (KG)	SURFACE FINISH	STATIC CAPACITY (KG)	WHEEL DIM. & WIDTH (mm)	DIM. A (mm)	
				MIN.	MAX.
17	HOT DIP GALV	800KG	260 x 65	920	1140
DIM. B TUBE \emptyset	DIM. C (MAX. TRAVEL) (mm)	DIM. D (mm)	DIM. E (mm)	DIM. F (mm)	
73.5mm	225	450	355	190	

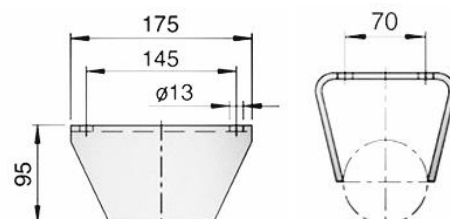
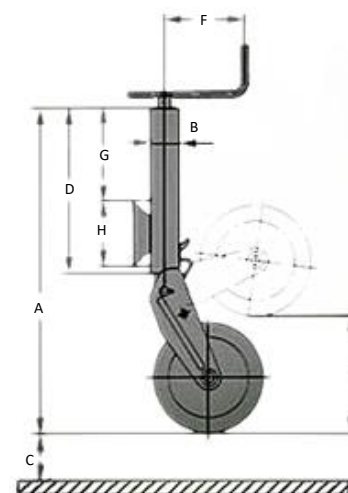



628200XP3
8 x 2 SOLID TYRE JOCKEY
WHEEL c/w 3 BOLT DOUBLE
LOCKING PIN SWIVEL BRACKET

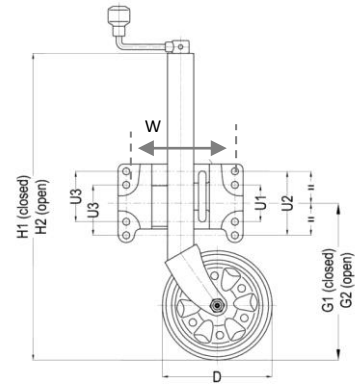

WEIGHT (KG)	SURFACE FINISH	STATIC CAPACITY (KG)	OUTER TUBE DIAMETER	D (mm)	H 1 (mm)	H 2 (mm)	G 1 (mm)	G 2 (mm)	W (mm)	U (mm) HOLE SIZE (ø14)		
										U 1	U 2	U 3
										FOR DRAW BAR DEPTH		
										50 mm	100 mm	75 mm
8.5	ZINC PLATED	400KG	48mm	200	570	820	305	522	185	63	113	88



623660XP3
250 x 80 SOLID TYRE JOCKEY
WHEEL c/w 3 BOLT DOUBLE
LOCKING PIN SWIVEL BRACKET

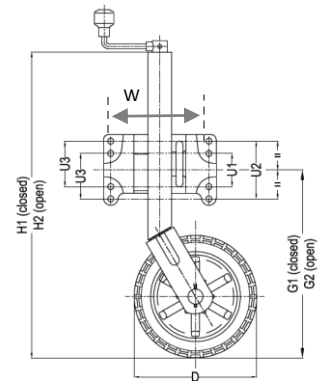

WEIGHT (KG)	SURFACE FINISH	STATIC CAPACITY (KG)	OUTER TUBE DIAMETER	D (mm)	H 1 (mm)	H 2 (mm)	G 1 (mm)	G 2 (mm)	W (mm)	U (mm) HOLE SIZE (ø14)		
										U 1	U 2	U 3
										FOR DRAW BAR DEPTH		
										50 mm	100 mm	75 mm
11	ZINC PLATED	400KG	48mm	250	630	880	320	570	185	63	113	88



628500
8 x 2 PREMIUM SIDE WIND JOCKEY
WHEEL c/w EXTRA WIDE CLAMP

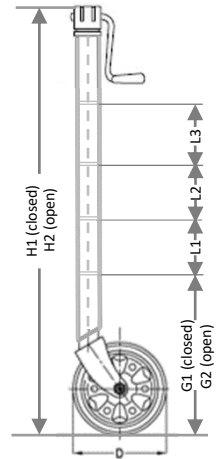

WEIGHT (KG)	SURFACE FINISH	STATIC CAPACITY (KG)	OUTER TUBE DIAMETER	D (mm)	H 1 (mm)	H 2 (mm)	G 1 (mm)	G 2 (mm)	L 1 (mm)	L 2 (mm)	L 3 (mm)
9.1	ZINC PLATED	400KG	48mm	200	771	1037	320	586	85	85	85



621250
250 x 80 SOLID TYRE POWER
MOVER JOCKEY WHEEL c/w CLAMP

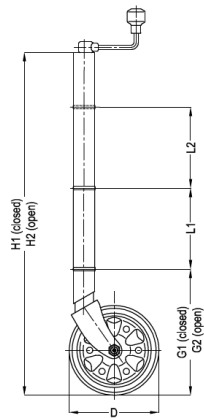

WEIGHT (KG)	SURFACE FINISH	STATIC CAPACITY (KG)	DYNAMIC CAPACITY (KG)	OUTER TUBE DIAMETER	D (mm)	H 1 (mm)	H 2 (mm)	G 1 (mm)	G 2 (mm)	L 1 (mm)	L 2 (mm)
14.7	ZINC PLATED	350KG	150KG	48mm	245	625	875	335	585	85	85

Helpful Hint: Use a large wheel for soft ground!

626050

T/T 6 x 2 LIGHT DUTY JOCKEY WHEEL c/w CLAMP

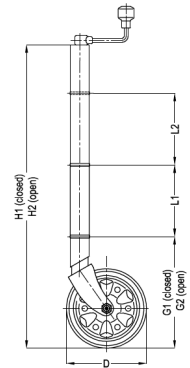

WEIGHT (KG)	SURFACE FINISH	STATIC CAPACITY (KG)	OUTER TUBE DIAMETER	D (mm)	H 1 (mm)	H 2 (mm)	G 1 (mm)	G 2 (mm)	L 1 (mm)
5	ZINC PLATED	350KG	48mm	150	510	760	202	457	180

629250TT

T/T 250 x 80 ZINC PLATED SOLID TYRE JOCKEY WHEEL c/w CLAMP



WEIGHT (KG)	SURFACE FINISH	STATIC CAPACITY (KG)	OUTER TUBE DIAMETER	D (mm)	H 1 (mm)	H 2 (mm)	G 1 (mm)	G 2 (mm)	L 1 (mm)
8	ZINC PLATED	350KG	48mm	245	635	885	325	575	180

Helpful Hint:

Use a large wheel for soft ground!

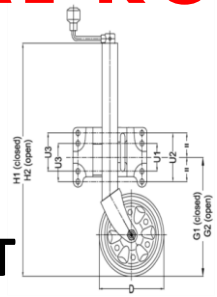

626190

**T/T 6 x 2 LIGHT DUTY JOCKEY WHEEL
c/w LARGE DOUBLE LOCKING PIN BRACKET**



WEIGHT (KG)	SURFACE FINISH	STATIC CAPACITY (KG)	OUTER TUBE DIAMETER	D (mm)	H 1 (mm)	H 2 (mm)	G 1 (mm)	G 2 (mm)	U (mm) HOLE SIZE (ø14)		
									U 1	U 2	U 3
									FOR DRAW BAR DEPTH		
									50 mm	100 mm	75 mm
6.75	ZINC PLATED	350KG	48mm	150	510	760	310	560	63	113	88

628200SLTT

**T/T 8 x 2 ZINC PLATED JOCKEY WHEEL
c/w LARGE DOUBLE LOCKING PIN BRACKET**



WEIGHT (KG)	SURFACE FINISH	STATIC CAPACITY (KG)	OUTER TUBE DIAMETER	D (mm)	H 1 (mm)	H 2 (mm)	G 1 (mm)	G 2 (mm)	U (mm) HOLE SIZE (ø14)		
									U 1	U 2	U 3
									FOR DRAW BAR DEPTH		
									50 mm	100 mm	75 mm
7.5	ZINC PLATED	350KG	48mm	200	570	820	310	560	63	113	88

629250SLTT

**T/T 250 x 80 ZINC PLATED JOCKEY WHEEL
c/w LARGE DOUBLE LOCKING PIN BRACKET**



WEIGHT (KG)	SURFACE FINISH	STATIC CAPACITY (KG)	OUTER TUBE DIAMETER	D (mm)	H 1 (mm)	H 2 (mm)	G 1 (mm)	G 2 (mm)	U (mm) HOLE SIZE (ø14)		
									U 1	U 2	U 3
									FOR DRAW BAR DEPTH		
									50 mm	100 mm	75 mm
10.5	ZINC PLATED	350KG	48mm	245	630	880	395	645	63	113	88

629900 JOCKEY WHEEL CLAMP



WEIGHT (KG)	SURFACE FINISH	OUTER TUBE DIAMETER	A (mm)	B ø (mm)
1	ZINC PLATED	48mm	150	13

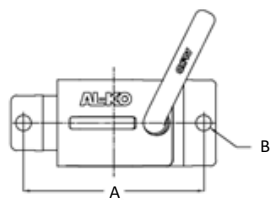

629920 LARGE DOUBLE LOCKING PIN BRACKET



WEIGHT (KG)	SURFACE FINISH	STATIC CAPACITY (KG)	OUTER TUBE DIAMETER	A (mm)	B (mm)	C (mm)	D (mm)
2.5	ZINC PLATED	400KG	48mm	185	88	63	113

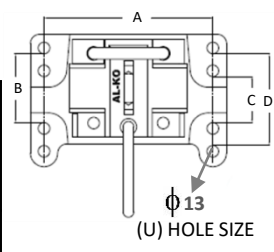

629923 SWIVEL BRACKET 3 BOLT LARGE



WEIGHT (KG)	SURFACE FINISH	STATIC CAPACITY (KG)	OUTER TUBE DIAMETER	A (mm)	B (mm)	C (mm)	D (mm)
2.65	ZINC PLATED	400KG	48mm	185	88	63	113

629935 DOUBLE LOCKING PIN BRACKET c/w CLAMP



WEIGHT (KG)	SURFACE FINISH	OUTER TUBE DIAMETER	A (mm)	B (mm)	C (mm)	D (mm)
3.3	ZINC PLATED	48mm	185	75	50	100



629600
6 x 2 SOLID
RUBBER WHEEL











629888
8 x 2 STEEL/
RUBBER WHEEL



629850
250 x 80 STEEL/
RUBBER WHEEL

Helpful Hint: Use a large wheel for soft ground!

PART NO.	DESCRIPTION	
626262	JOCKEY WHEEL U.BOLT KIT (75mm x 75mm)	
626260	JOCKEY WHEEL U.BOLT KIT (100mm x 75mm)	
629910	AK JOCKEY WHEEL MANOEUVRING HANDLE	
629915	AK JOCKEY WHEEL PREMIUM WIDE CLAMP (SPACING: 150mm x 50mm ; HOLE SIZE: 13mm)	
629602	STD. THRUST BEARING	
629601GS	JOCKEY WHEEL HANDLE c/w GRUB SCREW	
629601RP	JOCKEY WHEEL HANDLE c/w ROLL PIN	
629951	CLAMP HANDLE & BOLT	
629605	SCREWED SHAFT ONLY	